

# 10.1" Rugged Tablet PC

M101B

## Product Features:

- 10.1" 1920x1200 IPS LED Panel with P-Cap Touch
- Low-power system with Intel® BayTrail-M processor
- IP65 water and dust proof
- Optional Barcode or RFID Reader
- Dual Camera Design: 5MP Main camera with LED flash / 2MP Webcam
- Optional Expansion port for USB / RS232 connection
- Optional Hot-Swappable Battery Design / Optional high capacity battery pack
- 2 user-definable function keys



## Product Specifications:



System Specification	Processor	Intel Celeron N2920 Quad-Core 1.86GHz
	System Memory	4GB SODIMM DDR3L-1600
	Storage	64GB mSATA MLC SSD
	Operating System	Windows Embedded 8 Std. / Windows Embedded 8.1 Industry Pro / Windows Embedded Standard 7 (WS7P 64-bit)
Display Specification	Size	10.1"
	Resolution	1920x1200
	Brightness	700 nits
	Touch	Projective Capacitive Touch (min 4 points)
Wireless Communication	WLAN	802.11 a/b/g/n
	Bluetooth	Bluetooth 4.0 + Class I
	GPS	U-Blox Neo-6Q
	WWAN	3G - Sierra MC8090 (optional), 4G/LTE- Sierra MC7355/ Gobi5000 (optional), Sierra MC7305 / Gobi5000 (optional)
System I/O Buttons Indicators Sensors	Audio	1 x Built-in Mic, 2 x 1W Speaker
	External I/O	1 x Micro HDMI, 1 x 30-pin Combo Conn (LAN or RS232), 1 x USB3.0, 1 x Audio Combo Conn. (Mic in or Line Out), 1 x Power Jack, 1 x Micro SD Slot
	Buttons	1 x Power, 1 x Home, 2 x Function Key, 2 x Volume Key
	LED	Power, Battery, HDD, RF
	Sensors	Light sensor, G sensor, Gyrometer, E-compass
Data Capture	Camera	5MP Auto-Focus Camera with 1W LED Flash at rear / 2MP Camera at front side
	Barcode	1D/2D Barcode Reader (optional)
	RFID	HF RFID Reader (optional)
Mechanical and Environment	Dimension (W x L x H)	271.8 x 197.2 x 19 mm
	Weight	1.2kg
	Operating Temperature	-20°C to 60°C (AC Mode), -10°C to 50°C ( Battery Mode )
	Operating Humidity	30% ~ 90% (non condensing)
	IP Proof	IP65
	Shock	MIL-STD-810G Method 516.6 Procedure I
	Vibration	MIL-STD-810G Method 514.6 Procedure I
	Drop	MIL-STD-810G Method 516.6, 4 ft to concrete
Certifications	CE, FCC, UL 60950, EN60601**	
Power Management	Power Input	12-19V DC
	Battery	7.4V, 5300 mAh Li-Polymer Battery (2S1P) 7.4V, 10600 mAh Li-Polymer Battery (2S2P, optional)
	Battery Operating Time	8 hours (tested with MobileMark 2007)
	Adapter	100-240V, 50-60Hz / 19V DC

\*Note: this is a simplified drawing and some components are not marked in detail. Please contact our sales representative if you need further product information.

\*\*Note: EN60601 certified with optional power adapter for medical use

## Dimensions :

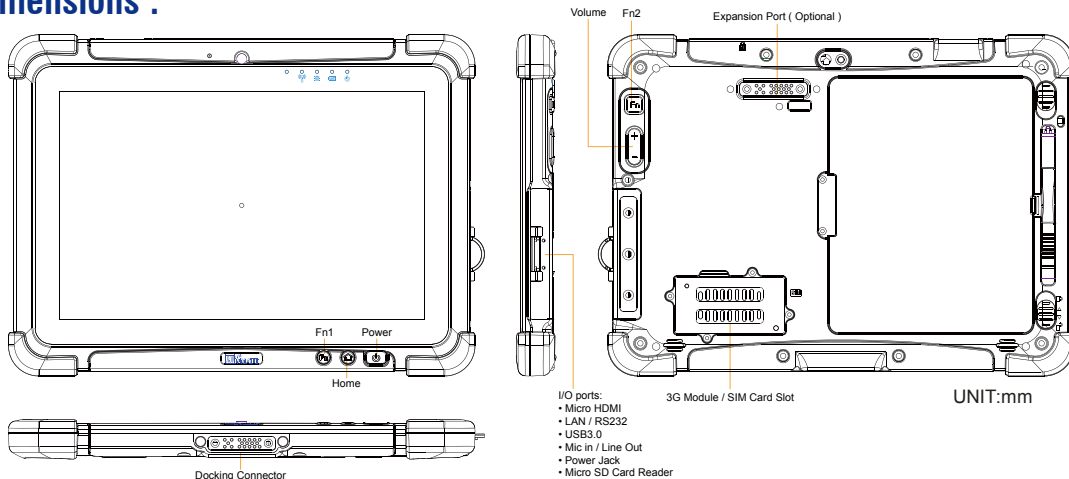

Accessories:	
1. 19V 65W Power Adapter x 1	
2. Power Cord x 1	
3. 7.4V / 5300mAh Battery x 1	
4. M101 Quick Start Guide x 1	
5. Manual & Driver CD x 1	
6. Capacitive Stylus x 1	

Order Information:	
M101B	Basic
M101B-3	3G MC-8090
M101B-LE	4G/LTE MC7305 for Europe
M101B-LA	4G/LTE MC7355 for North America

Battery	Flat	Vertical
Charging	0~40°C	0~45°C
Discharging	0~45°C	0~50°C

Rev.	Reasons	Revised Date
1.0	First Release	Apr.01.2014
1.1	Spec change	May.22.2014
1.2	Spec change	May.28.2014