

Absolute encoders - singleturn

Standard ATEX/IECEX – mining, optical	Sendix 7153 / 7173 (shaft / hollow shaft)	SSI / BiSS
---	--	-------------------



The Sendix 7153 / 7173 absolute singleturn encoders in a compact 70 mm stainless-steel housing, with an SSI or BiSS interface and optical sensor technology have an ATEX/IECEX mining approval.

These shock and vibration-resistant encoders operate flexibly with a resolution of up to 17 bits; they are also available with axial and radial cable outlets.

 Absolute encoders
singleturn

								Reverse polarity protection	Optical sensor
Ex approval	Safety-Lock™	High rotational speed	High protection level	High shaft load capacity	Shock / vibration resistant	Magnetic field proof	Short-circuit proof		

Compact and safe

- Can be used even when space is tight.
- Minimal installation depth, diameter 70 mm.
- Compact cable outlet axial or radial.
- Remains sealed even in harsh everyday use and ensures highest safety against field breakdowns (IP67 protection).

Explosion protection

- Mining approval.
- “Flame-proof enclosure” construction.
- ATEX with EC type examination certificate.
- IECEx with certificate of conformity (CoC).

Order code	8.7153	. 2 X 2 X . X X 2 1 . XXXX
Shaft version	Type	a b c d e f g h i ¹⁾

- | | | |
|--|--|--|
| <p>a Flange
2 = clamping / synchronous flange, IP67, ø 70 mm [2.76"]</p> <p>b Shaft (ø x L)
2 = 10 x 20 mm [0.39 x 0.79"], with flat
1 = 12 x 25 mm [0.47 x 0.98"], with keyway for 4 x 4 mm [0.16 x 0.16"] key</p> <p>c Interface / power supply
2 = SSI, BiSS / 10 ... 30 V DC</p> <p>d Type of connection
1 = axial cable, 2 m [6.56'] PUR
2 = radial cable, 2 m [6.56'] PUR
A = axial cable, length > 2 m [6.56']
B = radial cable, length > 2 m [6.56']</p> | <p>e Code
B = SSI, binary
C = BiSS, binary
G = SSI, gray</p> <p>f Resolution ²⁾
A = 10 bit
1 = 11 bit
2 = 12 bit
3 = 13 bit
4 = 14 bit
7 = 17 bit</p> | <p>g Inputs / outputs ²⁾
2 = SET, DIR input
additional status output</p> <p>h Options
1 = no option</p> <p>i Cable length in dm ¹⁾
0050 = 5 m [16.40']
0100 = 10 m [32.81']
0150 = 15 m [49.21']</p> <p><i>Optional on request</i>
- special cable length
- other resolutions</p> |
|--|--|--|

1) Not applicable with connection types 1 and 2
2) Resolution, preset value and counting direction factory-programmable.

Absolute encoders - singleturn

Standard ATEX/IECEx – mining, optical	Sendix 7153 / 7173 (shaft / hollow shaft)	SSI / BiSS
--	--	-------------------

Order code Hollow shaft	8.7173 Type	.XX2X.XX21.XXXX a b c d e f g h i 1)
a Flange 2 = with spring element, short 6 = with stator coupling, IP67, ø 65 mm [2.56"]	e Code B = SSI, binary C = BiSS, binary G = SSI, gray	g Inputs / outputs²⁾ 2 = SET, DIR input additional status output
b Blind hollow shaft 1 = ø 12 mm [0.47"] 2 = ø 14 mm [0.55"]	f Resolution²⁾ A = 10 bit 1 = 11 bit 2 = 12 bit 3 = 13 bit 4 = 14 bit 7 = 17 bit	h Options 1 = no option
c Interface / power supply 2 = SSI, BiSS / 10 ... 30 V DC		i Cable length in dm¹⁾ 0050 = 5 m [16.40'] 0100 = 10 m [32.81'] 0150 = 15 m [49.21']
d Type of connection 1 = axial cable, 2 m [6.56'] PUR 2 = radial cable, 2 m [6.56'] PUR A = axial cable, length > 2 m [6.56'] B = radial cable, length > 2 m [6.56']		<i>Optional on request</i> - special cable length - other resolutions

Technical data

Explosion protection 7153	
ATEX	
EC type-examination certificate	IBExU 14 ATEX 1047 X
Category	⊕ I M2 Ex d I/IIC T4 - T6 Mb
Directive 94/9/EC	EN 60079-0:2012; EN 60079-1:2007
IECEx	
Certificate of Conformity (CoC)	IECEx IBE 14.0023 X
Category	I M2 Ex d I/IIC T4 - T6 Mb
IECEx	IEC 60079-0:2011; IEC 60079-1:2007

Explosion protection 7173	
ATEX	
EC type-examination certificate	IBExU 15 ATEX 1057 X
Category	⊕ I M2 Ex d I/IIC T4 Mb
Directive 94/9/EC	EN 60079-0:2012; EN 60079-1:2014
IECEx	
Certificate of Conformity (CoC)	IECEx IBE 15.0019 X
Category	Ex d I/IIC T4 Mb
IECEx	IEC 60079-0:2011; IEC 60079-1:2014

Mechanical characteristics	
Maximum speed	6000 min ⁻¹ (continuous)
Starting torque - at 20°C [68°F]	< 0.05 Nm
Mass moment of inertia	4.0 x 10 ⁻⁶ kgm ²
Load capacity of shaft	radial 80 N axial 40 N
Weight	approx. 2.8 kg [98.77 oz]
Protection acc. to EN 60529	IP67
Working temperature range	-40°C ... +60°C [-40 ... +140°F]
Material	shaft stainless steel flange / housing stainless steel cable PUR
Shock resistance acc. to EN 60068-2-27	1000 m/s ² , 6 ms
Vibration resistance acc. to EN 60068-2-6	100 m/s ² , 55 ... 2000 Hz

Electrical characteristics	
Power supply	10 ... 30 V DC
Current consumption (no load)	max. 45 mA
Reverse polarity protection for power supply	yes
Short-circuit proof outputs	yes ³⁾
CE compliant acc. to	EMC guideline 2004/108/EC ATEX guideline 94/9/EC RoHS guideline 2011/65/EU

1) Not applicable with connection types 1 and 2
 2) Resolution, preset value and counting direction factory-programmable.
 3) Short-circuit with 0 V or output, only one channel at a time, power supply correctly applied.

Absolute encoders - singleturn

Standard ATEX / IECEx – mining, optical	Sendix 7153 / 7173 (shaft / hollow shaft)	SSI / BiSS
--	--	-------------------

SSI interface	
Output driver	RS485 transceiver type
Permissible load / channel	max. +/- 20 mA
Signal level	HIGH typ 3.8 V LOW at I _{Load} = 20 mA typ 1.3 V
Resolution	10 ... 14 bit and 17 bit
Code	binary or gray
SSI clock rate	50 kHz ... 2 MHz
Monoflop time	≤ 15 μs
Note: if clock starts cycling within monoflop time a second data transfer starts with the same data. If clock starts cycling after monoflop time, the data transfer starts with updated values. The update rate depends on clock speed, data length and monoflop time.	
Data refresh rate	resolution ≤ 14 bit < 1 μs resolution ≥ 15 bit 4 μs

BiSS interface	
Resolution	10 ... 14 bit and 17 bit
Code	binary
Clock rate	up to 10 MHz
Max. update rate	< 10 μs, depends on the clock rate and the data length
Data refresh rate	≤ 1 μs
Note: <ul style="list-style-type: none"> – Bidirectional, factory programmable parameters are: resolution, code, direction, alarms and warnings – CRC data verification 	

Power-ON time
After Power-ON, the device requires a time of approximately 150 ms before valid data can be read.

SET input	
Input	HIGH active
Input type	comparator
Signal level (+V = power supply)	HIGH min. 60 % of +V max. +V LOW max. 25 % of +V
Input current	< 0.5 mA
Min. pulse duration (SET)	10 ms
Timeout after SET signal	14 ms
Response time (DIR input)	1 ms
The encoder can be set to zero at any position by means of a HIGH signal on the SET input. Other preset values can be factory-programmed. The SET input has a signal delay time of approximately 1 ms. Once the SET function has been triggered, the encoder requires an internal processing time of approximately 15 ms before the new position data can be read.	

Status output	
Output driver	open collector, internal pull-up resistor 22 kΩ
Permissible load	max. 20 mA
Signal level	HIGH +V LOW < 1 V
Active at	LOW
The status output serves to display various alarm or error messages. The status output is HIGH (open collector with internal pull-up 22 kΩ) in normal operation.	

DIR input
A HIGH signal switches the direction of rotation from the default CW to CCW. The reverse function can also be factory-programmed.
If DIR is reversed when the device is already switched on, this will be interpreted as an error. The status output switches to LOW.

Terminal assignment

Interface	Type of connection	Features	Cable (isolate unused wires individually before initial start-up)												
			Signal:	0 V	+V	C+	C-	D+	D-	SET	DIR	Stat	⊥	⊥	
2	1, 2, A, B	SET, DIR	Cable marking:	1	2	3	4	5	6	7	8	9	YE/GN	shield	

- +V: Encoder power supply +V DC
- 0 V: Encoder power supply ground GND (0 V)
- C+, C-: Clock signal
- D+, D-: Data signal
- SET: Set input. The current position becomes defined as position zero.

- DIR: Direction input: If this input is active, output values are counted backwards (decrease) when the shaft is turning clockwise.
- Stat: Status output
- ⊥: Protective earth

Absolute encoders - singleturn

Standard
ATEX/IECEX – mining, optical

Sendix 7153 / 7173 (shaft / hollow shaft)

SSI / BiSS

Dimensions shaft version

Dimensions in mm [inch]

Clamping / synchronous flange, \varnothing 70 [2.76]
Shaft type 1 with axial cable outlet

- 1 9 x M4, 10 [0.39] deep
- 2 Keyway for DIN 6885-A-4x4x25 key

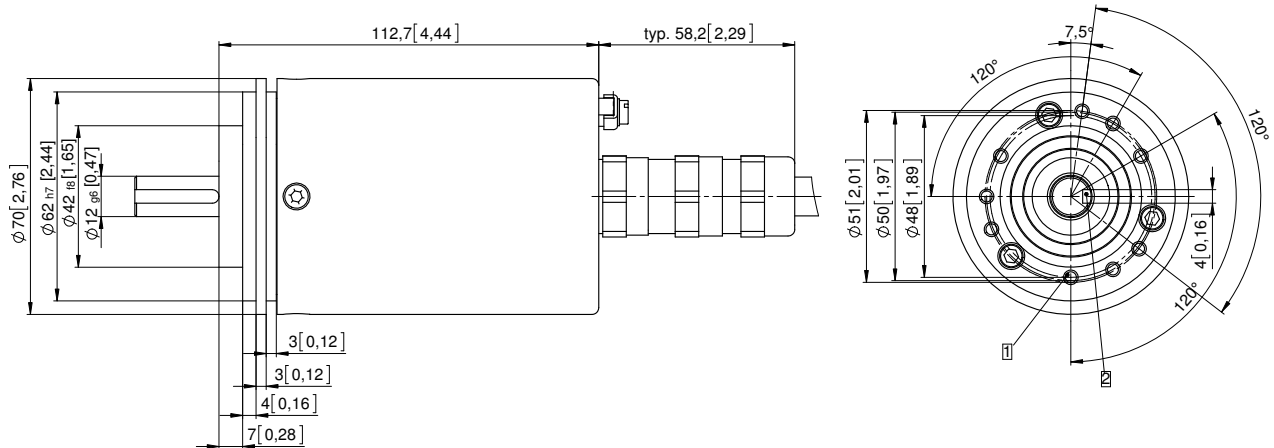

Clamping / synchronous flange, \varnothing 70 [2.76]
Shaft type 2 with radial cable outlet

- 1 9 x M4, 10 [0.39] deep

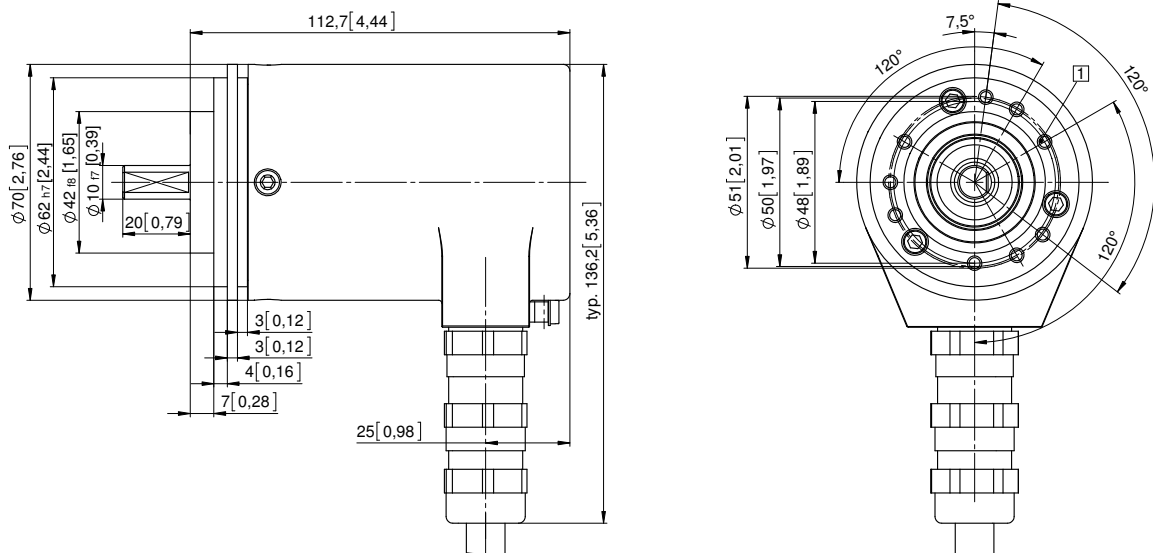

Absolute encoders - singleturn

Standard ATEX/IECEX – mining, optical	Sendix 7153 / 7173 (shaft / hollow shaft)	SSI / BiSS
--	--	-------------------

Dimensions hollow shaft version

Dimensions in mm [inch]

Flange with spring element, short Flange type 2

- 1 9 x M4, 10 [0.39] deep
- 2 Torque stop slot, recommendation: cylindrical pin DIN7, 4 [0.16]
- 3 Recommended torque for the clamping ring 2,5 Nm

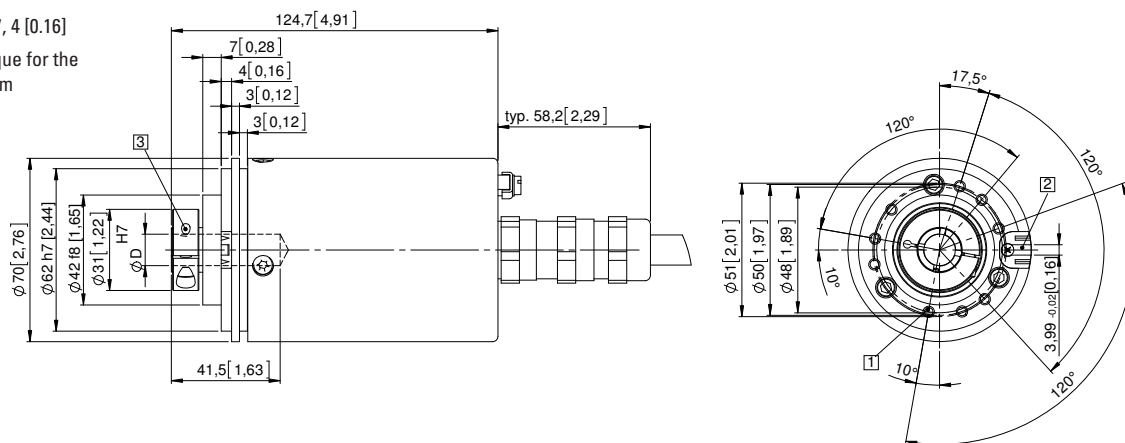

Flange with stator coupling, $\varnothing 65$ [2.56]

Flange type 6

- 1 Recommended torque for the clamping ring 2,5 Nm

